

HÄFELE REFRIGERATOR STANDARD HINGE

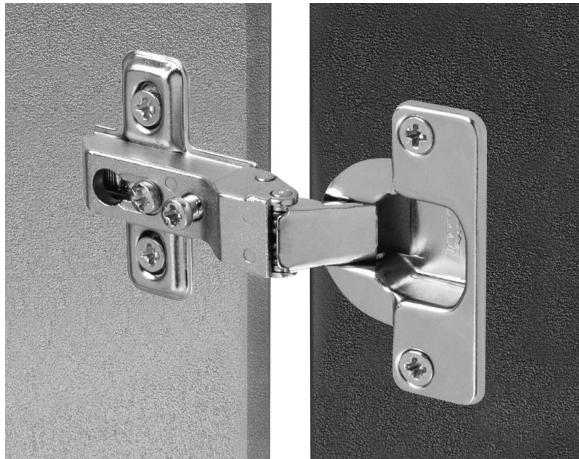

- > Opening angle 110°, Ø 35 mm cup
- > Screw fixing cup
- > Keyhole fixing arm
- > For door thicknesses up to 22 mm see table left
- > Full overlay mounting steel cup and zinc alloy hinge arm
- > Not soft close compatible
- > Order fixing screws separately
- > Order qty: 1 pc

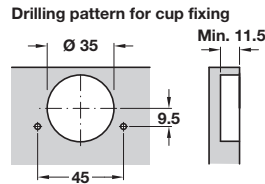

Häfele refrigerator hinge

Minimum gap for doors with chamfered edges (r = 1 mm) with factory setting

| Door thickness mm | Distance to cup E mm | | |
|----------------------|----------------------|-----|-----|
| | 3.0 | 4.0 | 5.0 |
| 16 | 0.3 | 0.3 | 0.3 |
| 17 | 0.5 | 0.5 | 0.5 |
| 18 | 0.7 | 0.7 | 0.7 |
| 19 | 1.0 | 0.9 | 0.9 |
| 20 | 1.3 | 1.2 | 1.2 |
| 21 | 1.7 | 1.6 | 1.5 |
| 22 | 2.5 | 2.1 | 2.0 |
| Minimum gap F | | | |

Key-hole system

- Miniprimat series
- Special hinges

The hinge is assembled on the mounting plate inserting the fixing screw on the appropriate hole on the hinge arm. After adjusting the door depth, the mounting procedure is finished by tightening the fixing screw.

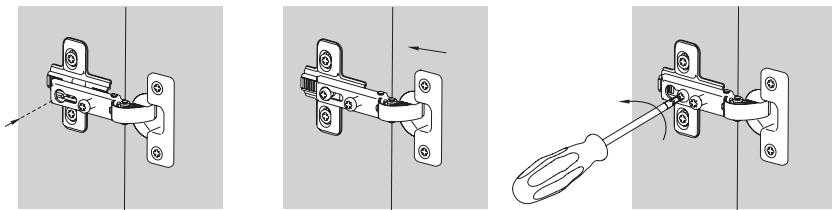

110° Hinge for cabinet with refrigerator

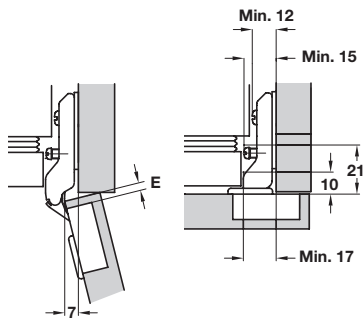

Fixing
Screw fixing



Keyhole fixing
312.50.500

YOU ALSO NEED:

MOUNTING PLATES
Page 328

FIXING SCREWS
Page 468

OPTIONAL ACCESSORIES
Pages 403-417

Keyhole mounting plate for Häfele concealed mini hinges and refrigerator hinge

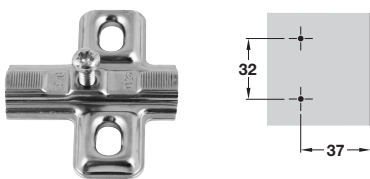

- > Hospa screw fixing
- > For use with mini hinges and refrigerator hinge
- > One part plate with ± 2 mm height adjustment via slots
- > Nickel-plated steel
- > Order fixing screws separately
- > Order qty: 1 pc



Height
0 mm
Hospa screw
312.46.510



A wider range of mounting plates are shown on pages **328**

HÄFELE REFRIGERATOR STANDARD HINGE



- > Opening angle 110°, Ø 35 mm cup
- > Screw fixing cup
- > Keyhole fixing arm
- > For door thicknesses up to 22 mm see table left
- > Full overlay mounting steel cup and zinc alloy hinge arm
- > Not soft close compatible
- > Order fixing screws separately
- > Order qty: 1 pc

Drilling pattern for cup fixing

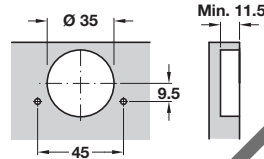

Häfele refrigerator hinge

Minimum gap for doors with chamfered edges (r = 1 mm) with factory setting

| Door thickness mm | Distance to cup E mm | | |
|-------------------|----------------------|-----|-----|
| | 3.0 | 4.0 | 5.0 |
| 16 | 0.3 | 0.3 | 0.3 |
| 17 | 0.5 | 0.5 | 0.5 |
| 18 | 0.7 | 0.7 | 0.7 |
| 19 | 1.0 | 0.9 | 0.9 |
| 20 | 1.3 | 1.2 | 1.2 |
| 21 | 1.7 | 1.6 | 1.5 |
| 22 | 2.5 | 2.1 | 2.0 |

Minimum gap F

Key-hole system

- Miniprimat series
- Special hinges

The hinge is assembled on the mounting plate inserting the fixing screw on the appropriate hole on the hinge arm. After adjusting the door depth, the mounting procedure is finished by tightening the fixing screw.

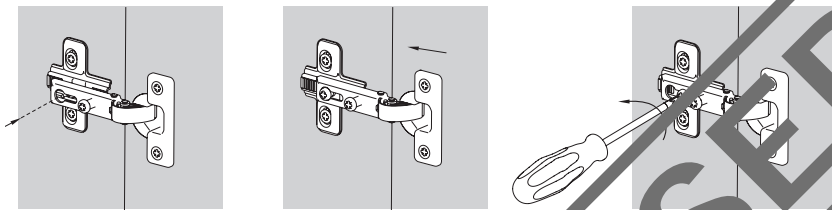

110° Hinge for cabinet with refrigerator

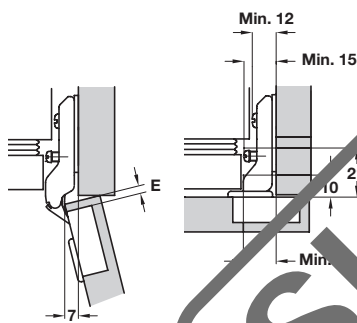

Fixing
Screw fixing



Keyhole fixing
312.50.500

YOU ALSO NEED:

MOUNTING PLATES
Page 328

FIXING SCREWS
Page 468

OPTIONAL ACCESSORIES
Pages 403-417

Keyhole mounting plate for Häfele concealed mini hinges and refrigerator hinge

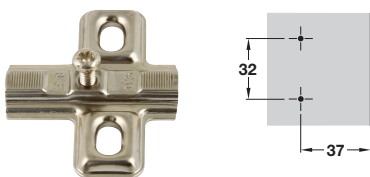

- > Hospa screw fixing
- > For use with mini hinges and refrigerator hinge
- > One part plate with ± 2 mm height adjustment via slots
- > Nickel-plated steel
- > Order fixing screws separately
- > Order qty: 1 pc



Height
0 mm
Hospa screw
312.46.510



A wider range of mounting plates are shown on pages **328**